



LOGSUB





SUMMARY

- ***HISTORY OF LOGSUB;***
- ***PARTNER COMPANIES;***
- ***PROJECTS IN PROGRESS;***
- ***CONCLUSION.***





HISTORY

LOGSUB was founded in 2008 with the purpose of developing Projects and Logistic Solutions for the submarines of the Brazilian and other South American Navies, as well as offering various services to surface naval units and to the Off-Shore market, by employing associated companies.

In this brief period, the company specialized in the area of Submarine Rescue and Salvage, Recovery and Underwater Activities, Development and Management of Naval Repairs, Study and Management of Projects of Public-Private Partnership (PPP) and Nationalization of Items and Systems for Submarines and Ships, in partnership with other national companies.



HISTORY



The company, in order to extend its expertise and become a national reference in its field, has participated of international fairs and conferences, thus widening technological knowledge, with emphasis on:

- NATO SMERWG (Submarine Escape and Rescue Working Group), since 2003; and
- LAAD 2009, 2011 e 2013 (RJ) as an exhibitor and speaker at the Symposiums of Defense and Strategy.



HISTORY



The company is affiliated to ABIMDE (Brazilian Association of Defense Material Industries) since OCT2008 and SMERAS (Submarine Escape Rescue and Abandonment Systems, a NATO Association) since FEB2008.



HISTORY

LOGSUB is a truly national company, in expansion, with ability to gather technicians, engineers and experts with wide experience in submarines, as well as offering expert advisors instructing and monitoring of large projects.





LOGSUB

PARTNER COMPANIES

AGI

ANALOX

TTS

BABCOCK

TRELLEBORG

JAMES FISHER DEF.

THYSSEN KMS

SAUER

TEXCON

SURVEY Eng.

ELAC



ONGOING PROJECTS

- **Development and nationalization of the environmental control system (CO₂ Absorption and O₂ Generation) and atmosphere monitoring for the SNBR (National Version / Wellman);**
- **Management, Repair and Maintenance of the BN ships at the Naval Base of Rio de Janeiro in the areas of structure and pipeworks;**
- **Project of the SCT central eye of the hatch for coupling the Submarine Rescue Bell (SRS);**
- **Project of a OC Transfer Station for the NT Marajó;**
- **PPP of the future Naval Village for the new BN Submarine Base;**
- **Development of a new and modern communication network in HF/LF and VLF for the BN with Babcock UK (SisGAAz);**



ONGOING PROJECTS

- **Development of a new Submarine Rescue System.**
- **Repowering project of the SCTs.**
- **Supply of the Shiplift for the future BN Submarine Base.**
- **Supply of a Shiplift and a transfer system for the Shipyard SIMA-Callao, Peru.**
- **Supply of a transfer system of the submarines UFEN – EBN.**
- **Development and supply of the escape and flooding simulators for the future submarine base.**
- **Management of the nationalization of PROSUB / BR SSN strategic items.**

ONGOING PROJECTS

- **Development and nationalization of the environmental control system (CO₂ Absorption and O₂ Generation) and atmosphere monitoring for the SNBR (National Version / Wellman);**

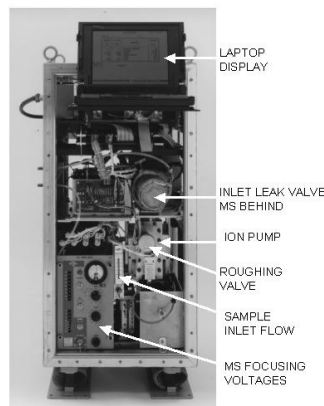
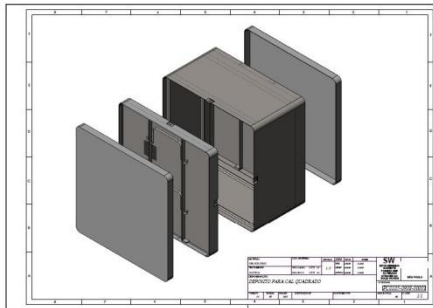

ONGOING PROJECTS

- **Management, Repair and Maintenance of the BN ships at the Naval Base of Rio de Janeiro in the areas of structure and pipeworks; and adaptation of the SCT hatch for the coupling of a SRS.**

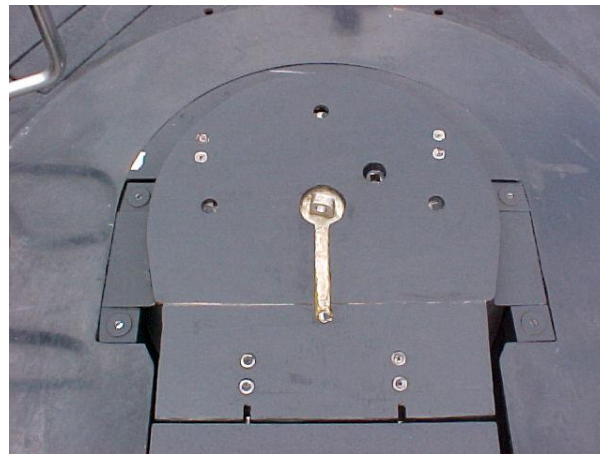
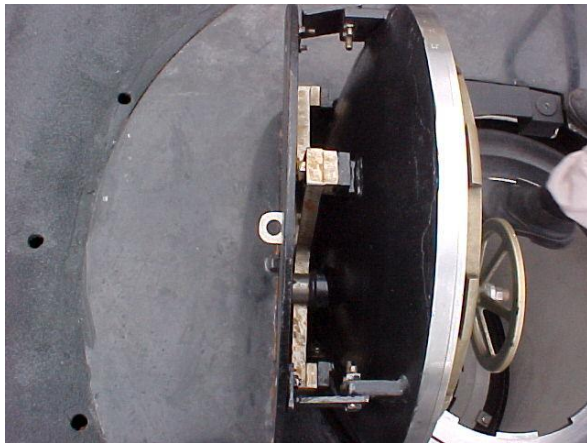

ONGOING PROJECTS

- Project of a OC Transfer Station at the stern of NT Marajó;

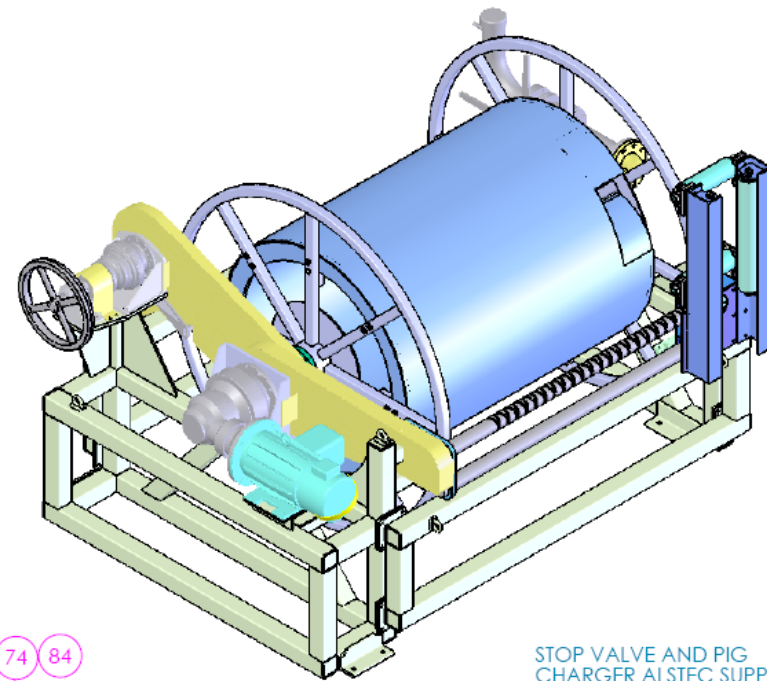
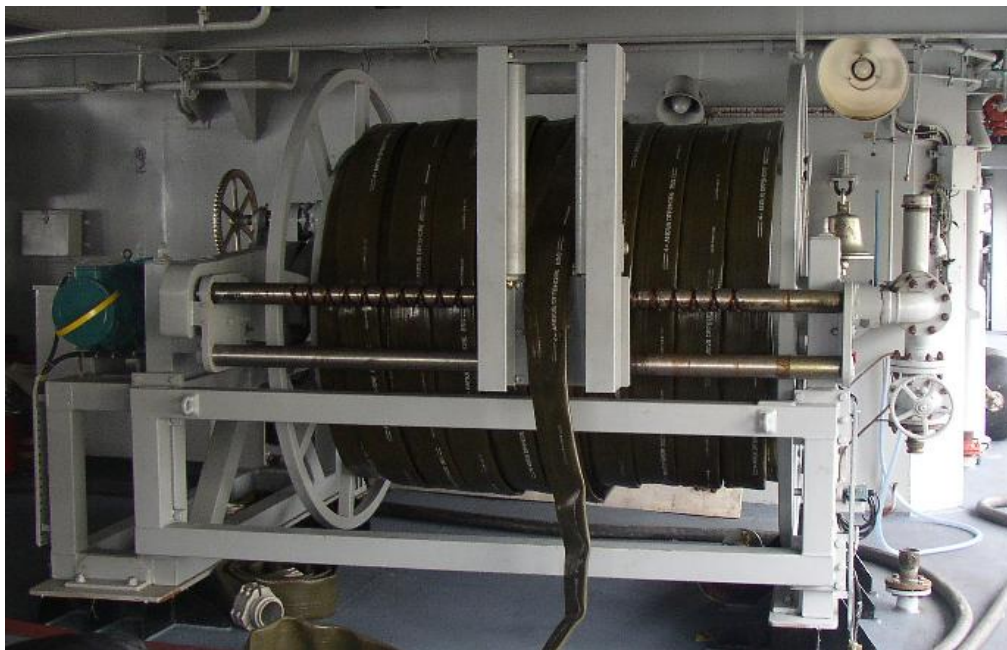

74 84

STOP VALVE AND PIG
CHARGER ALSTEC SUPPLY →

ONGOING PROJECTS

- PPP of the future Naval Village for the new BN Submarine Base



ONGOING PROJECTS

- Development of a new and modern communication network in HF/LF and VLF for the BN with Babcock UK;

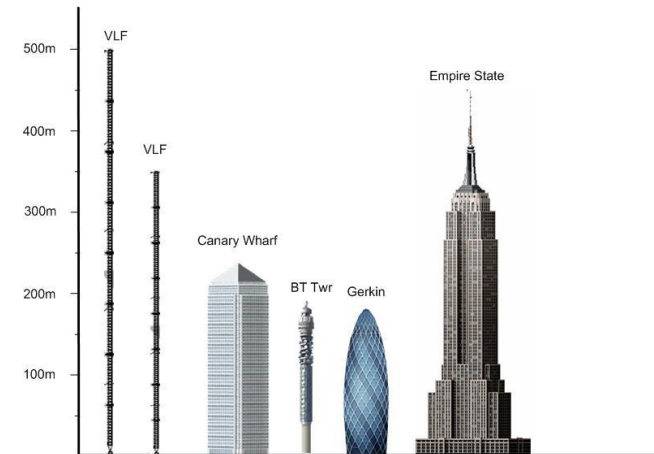

ONGOING PROJECTS

- **Development of a new Submarine Rescue System.**

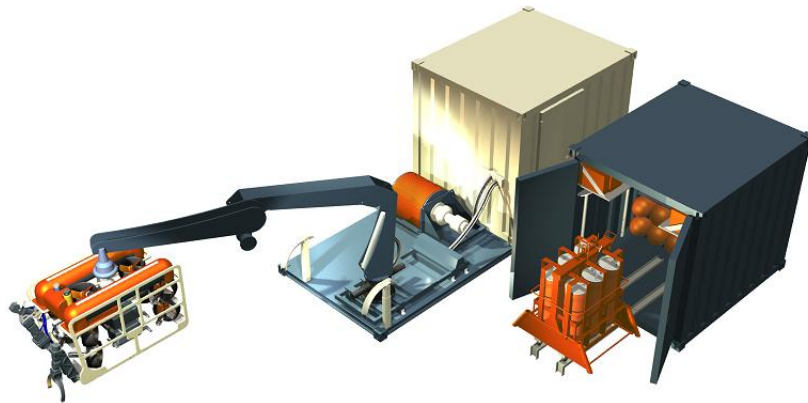

ONGOING PROJECTS

- Repowering project of the SCTs.



ONGOING PROJECTS

- Supply of the Shiplift for the future BN Submarine Base.



ONGOING PROJECTS

- **Development and supply of the escape and flooding simulators for the future submarine base.**

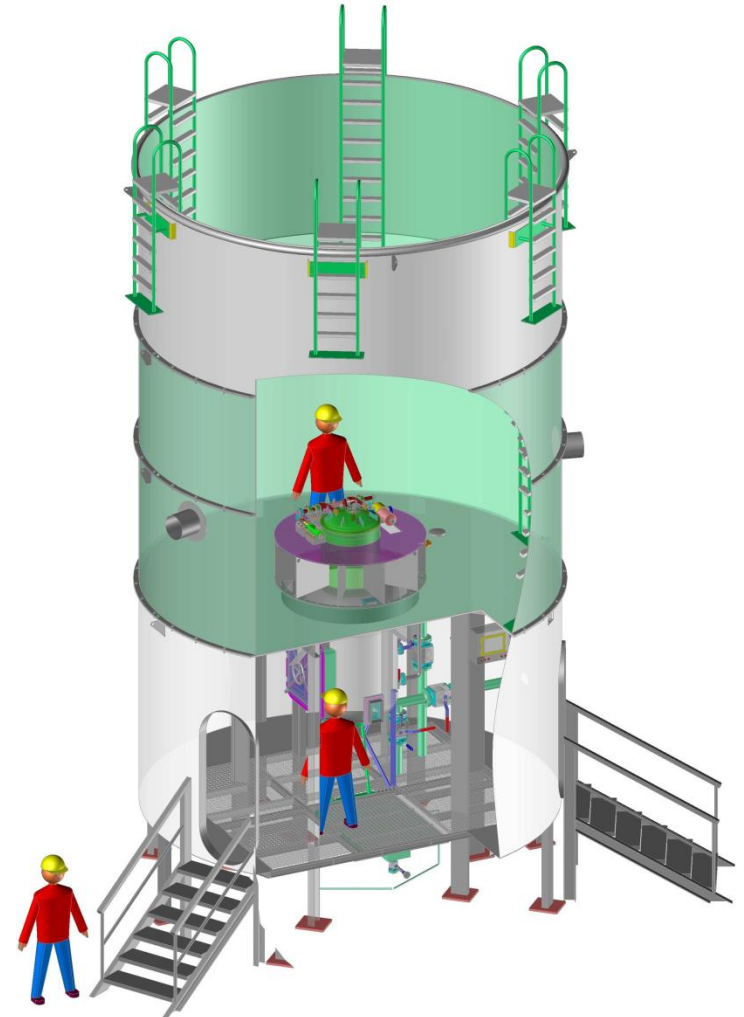
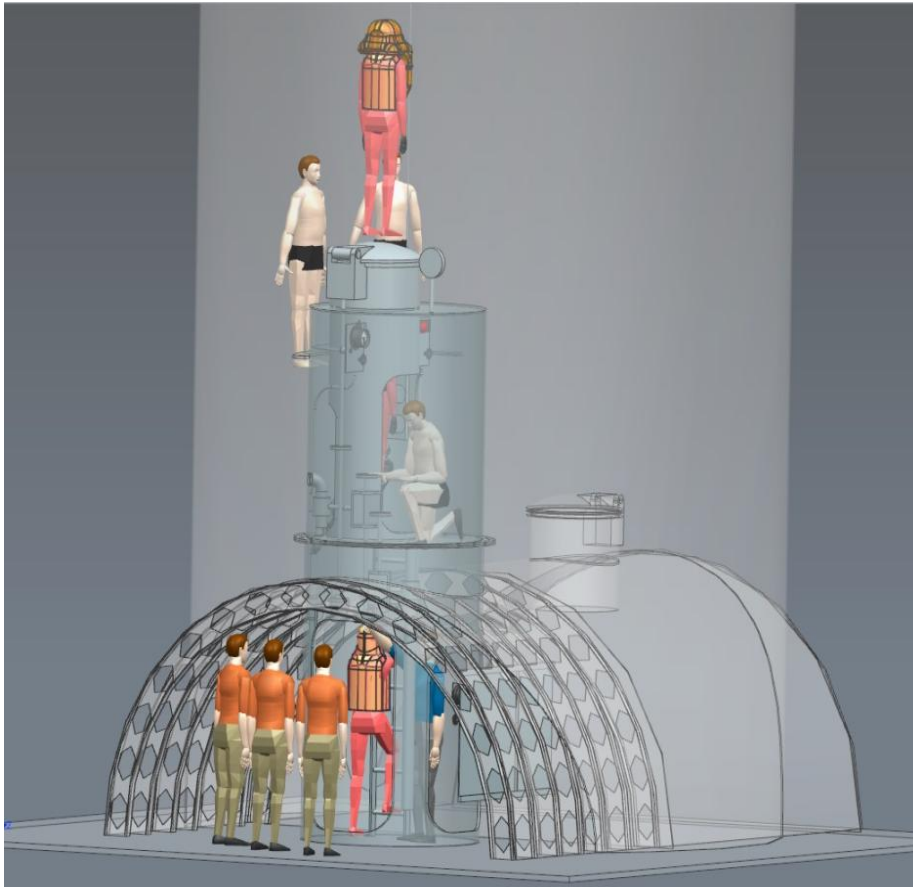

ONGOING PROJECTS

- Supply of a transfer system of the submarines UFEN – EBN.





ONGOING PROJECTS

- Supply of a Shiplift and a Transfer System for the Shipyard SIMA-Callao, Peru.



SIMA

SERVICIOS INDUSTRIALES DE LA MARINA
CONSTRUCTORES Y REPARADORES NAVALES DESDE 1845



RESUMEN DE INVERSIONES DEL PIP ARSENAL NAVAL CALLAO

ITEM	DETALLE	PRIMERA ETAPA		SEGUNDA ETAPA
		AÑO 1	AÑO 2	AÑO 3
1.00	Estudios	3,111,087	0	1,252,051
1.01	Expediente técnico	3,111,087	0	1,252,051
2.00	Instalaciones para ofrecer los servicios de reparaciones y construcciones navales	103,870,447	32,592,191	99,485,541
2.01	Construcción del patio de reparaciones y construcciones navales	65,909,942	19,878,264	40,494,527
2.02	Adquisición de sistema de puesta en seco de naves y transferencia a parqueos en sistema rígido	37,960,505	12,713,927	23,210,782
2.03	Capacitación para el sistema de puesta en seco de naves y transferencia a parqueos	0	0	0
2.04	Adquisición de equipamiento y maquinaria			35,780,232
3.00	Talleres con adecuado soporte logístico para atender las reparaciones y construcciones navales	24,387,786	0	57,909,636
3.01	Mejoramiento de infraestructura de talleres existentes			13,043,773
3.02	Adquisición de equipamiento y maquinaria para talleres, Desinstalación e instalación	4,164,233	0	32,056,714
3.03	Construcción de hangar para reparación mayor de unidades submarinas	7,532,365	0	0
3.04	Adquisición de equipos y herramientas para hangar de reparación mayor de unidades submarinas	3,562,593	0	0
3.05	Adquisición de mobiliario para talleres			689,357
3.06	Mejoramiento y rehabilitación de sub estaciones eléctricas para talleres	9,128,596		12,119,793

ITEM	DETALLE	PRIMERA ETAPA		SEGUNDA ETAPA
		AÑO 1	AÑO 2	AÑO 3
4.00	Taller para construcciones navales con capacidad operativa	7,000,551	0	11,973,952
4.01	Mejoramiento del taller de construcciones navales (taller X-40)	0	0	4,454,304
4.02	Adquisición de maquinaria y equipos del taller de construcciones navales (taller x-40)	7,000,551	0	7,519,648
5.00	Gradas operativas para las construcciones navales	23,516,089	0	5,516,121
5.01	Construcción de vigas carrileras	10,751,297	0	3,807,661
5.02	Adquisición del sistema de izaje y transporte (grúa pórtico) de módulos en gradas	12,764,792	0	1,708,460
6.00	Plataforma informática implementada para el diseño de unidades navales	0	0	1,056,984
6.01	Adquisición de hardware para diseño de unidades navales	0	0	157,902
6.02	Adquisición de licencia de software para diseño de unid.navales	0	0	899,082
7.00	Supervisión	1,642,240	1,033,702	3,234,800
7.01	Contratación de consultoría para supervisión de obra	1,642,240	1,033,702	3,234,800
8.00	Medidas de mitigación de impacto ambiental	971,800	828,375	1,499,675
8.01	Medidas de mitigación de impacto ambiental	971,800	828,375	1,499,675
9.00	Evaluación intermedia	0	0	1,200,000
9.01	Evaluación intermedia		0	1,200,000
	Inversión total por año	164,500,000	34,454,267	183,128,761
	Inversión total por etapa	198,954,267		183,128,761

REQUIREMENTS AND INVESTMENTS TO BE DONE FOR THE SHIPYARD

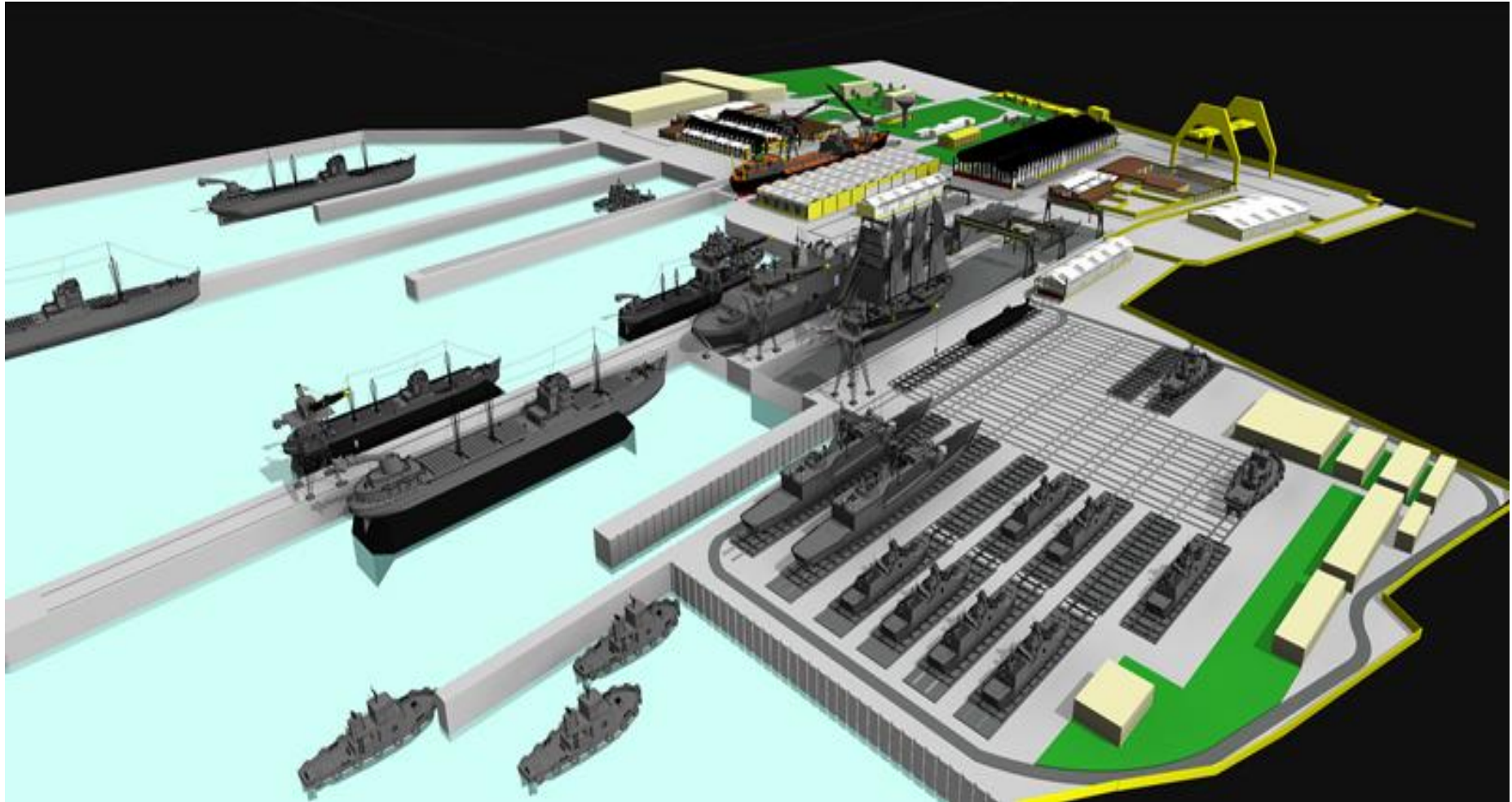

HANGAR DE SUBMARINOS

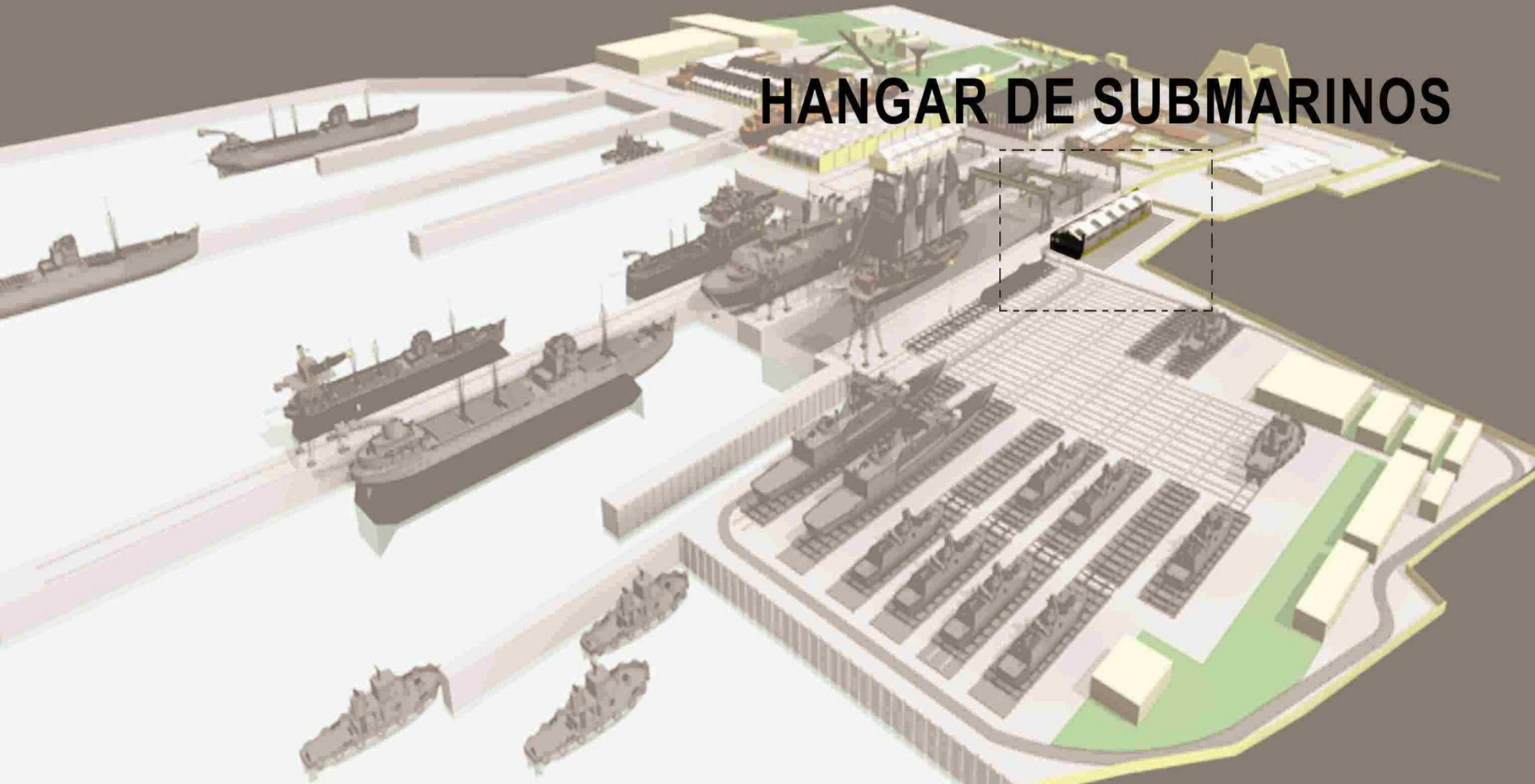

HANGAR



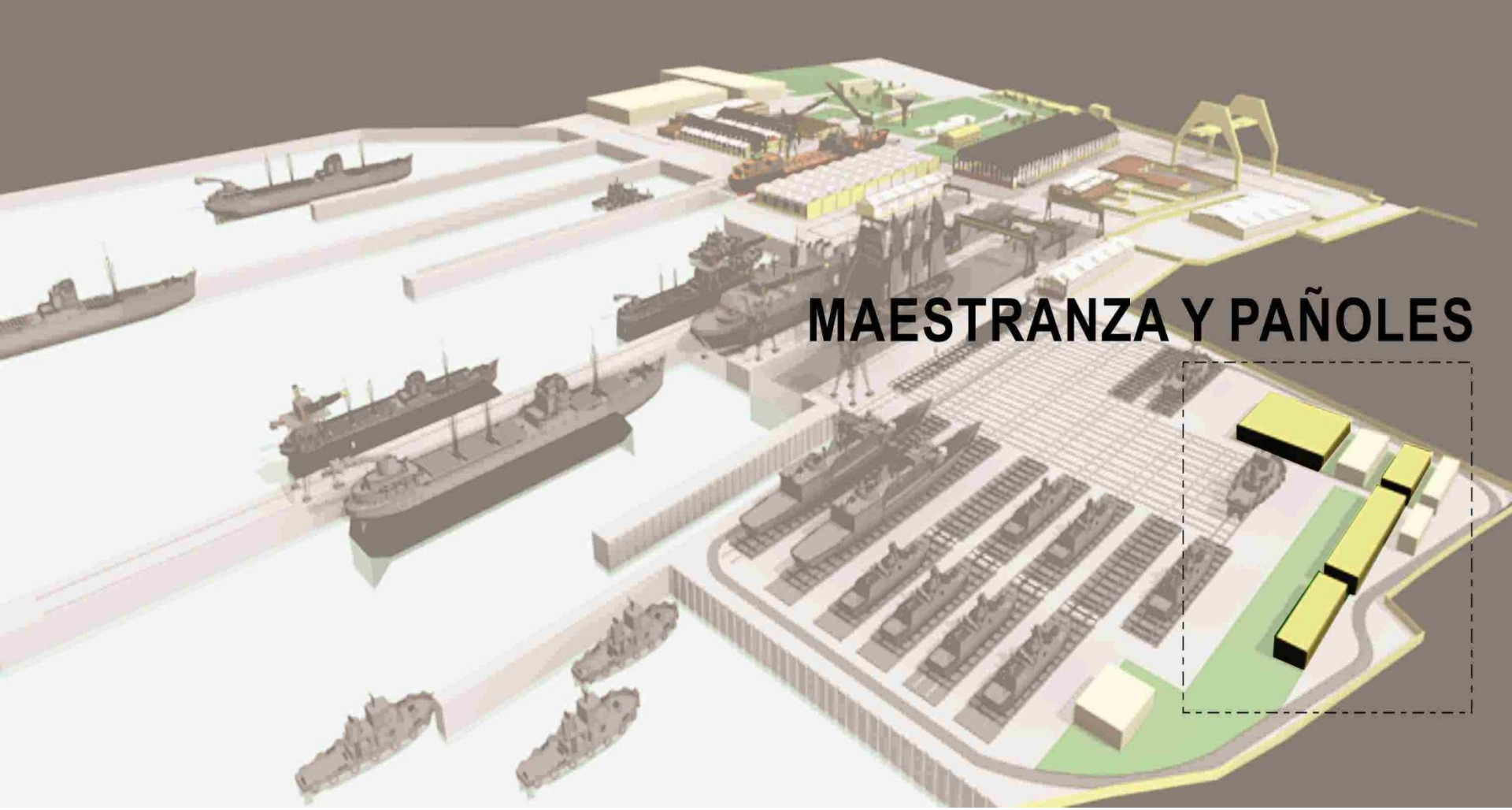

MAESTRANZA Y PAÑOLES

PARQUEADEROS

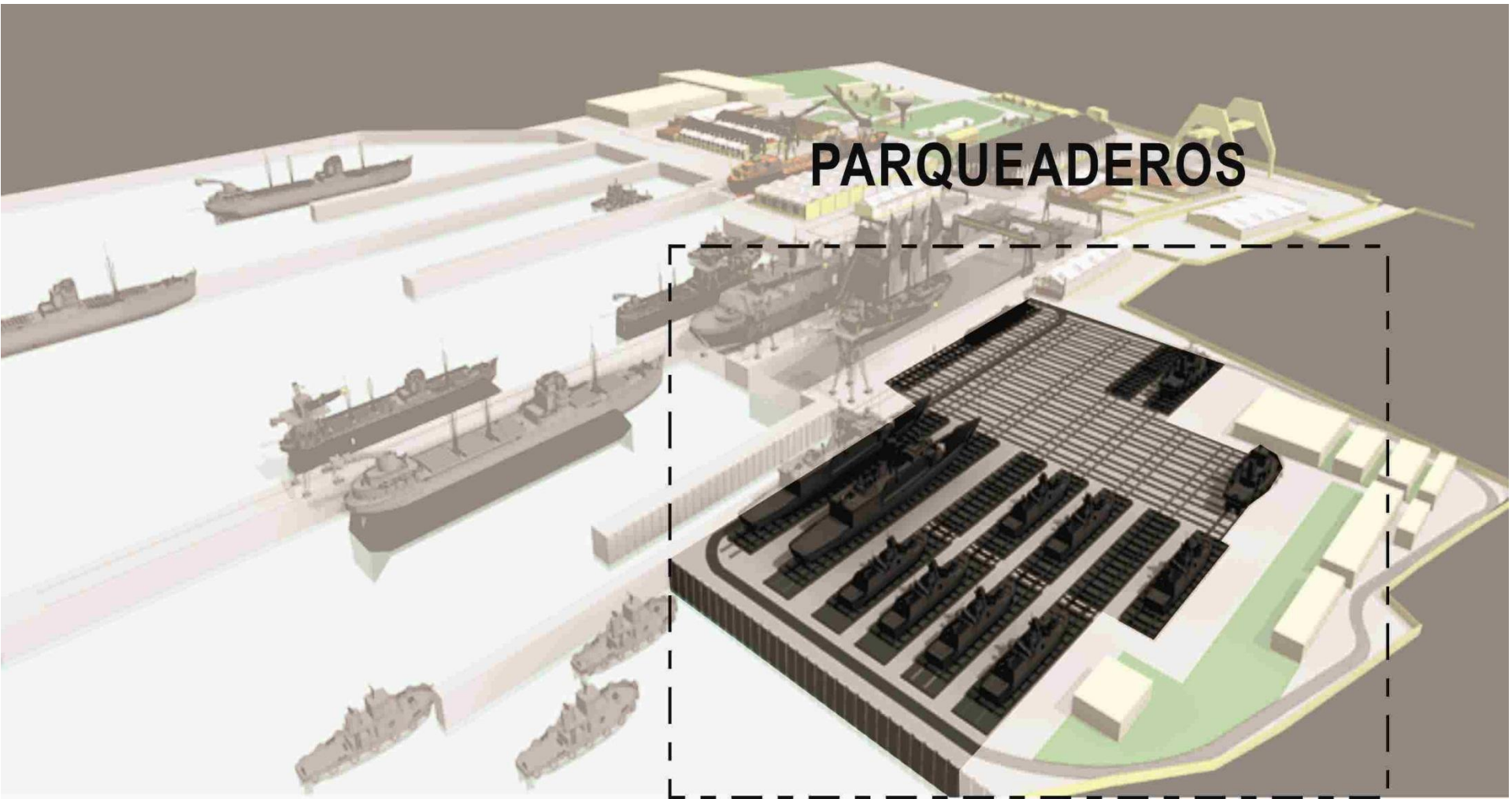



NO.	DESCRIPCION	AREA (M ²)	VOLUMEN (M ³)
1
2
3
4
5
6
7
8
9
10
11
12
13
14
15
16
17
18
19
20
21
22
23
24
25
26
27
28
29
30
31
32
33
34
35
36
37
38
39
40
41
42
43
44
45
46
47
48
49
50

- LEYENDA**
- ZONA MARITIMA
 - EDIFICACIONES ETAPA 1
 - EDIFICACIONES ETAPA 2
 - PROYECTO DE MAQUINARIAS
 - USUARIOS
 - OBRERA EN VIGILANCIA ETAPA 1
 - OBRERA EN VIGILANCIA ETAPA 2
 - BUSH (ETAPA 1)
 - ZONA DE TRANSFERENCIA DE FONDOS MAQUINARIAS (ETAPA 1)
 - ZONA DE TRANSFERENCIA DE FONDOS USUARIOS (ETAPA 2)
 - ZONA DE TRANSFERENCIA DE FONDOS MAQUINARIAS (ETAPA 2)
 - BARRIO (ETAPA 1)
 - FUENTE DE CONTRIBUCIONES (ETAPA 1)
 - PROYECION DE TRAYECTORIA OVAL (ETAPA 1)

2.01 DREDGING

ETAPA 1

Item	Descripción	Total
1	Dragado	9,532,056

ETAPA 2

Item	Descripción	Total
1	Dragado	2,925,997



ACQUISITION OF A SHIPLIFT AND A TRANSFER SYSTEM

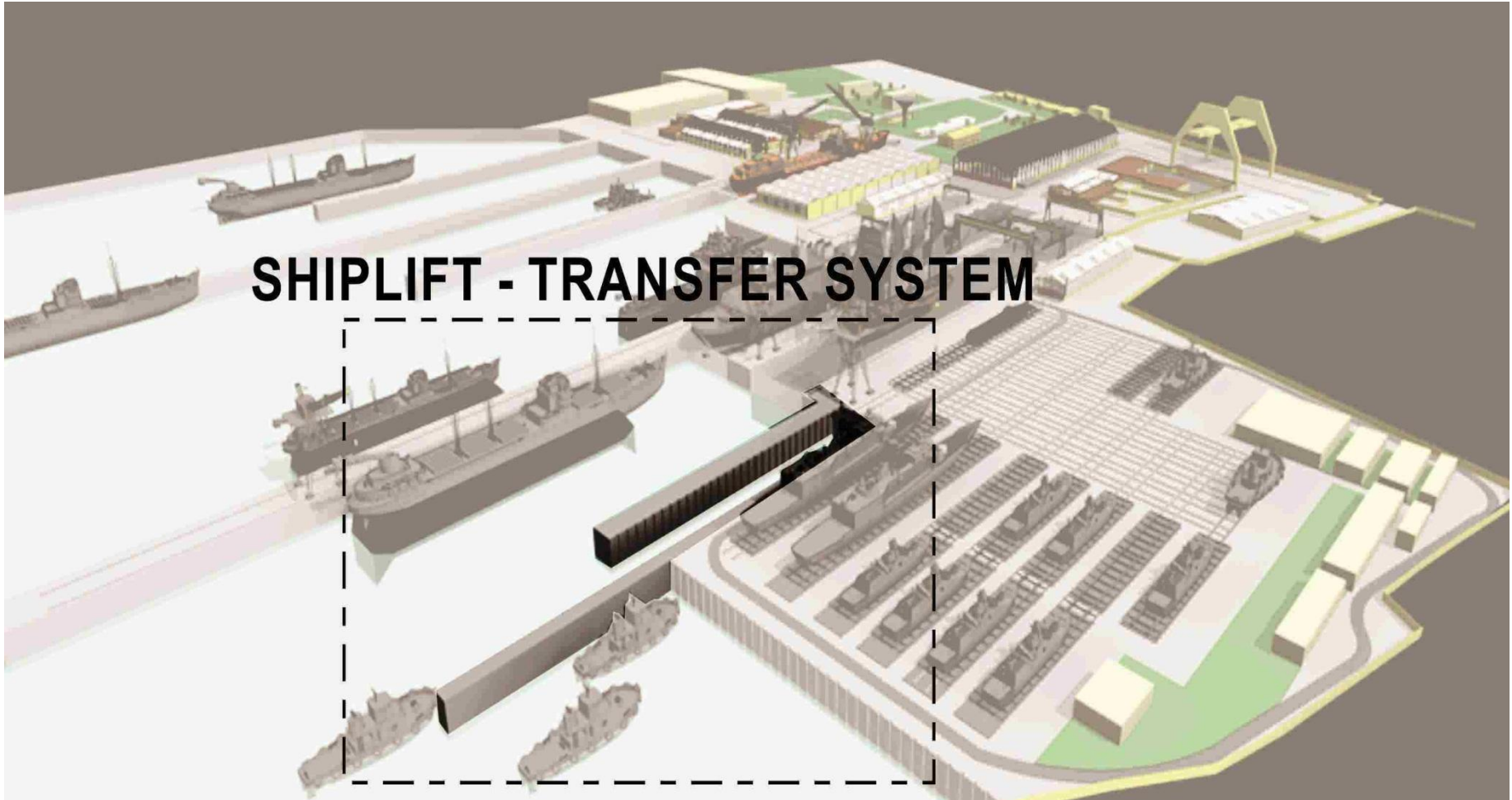

PLATFORM

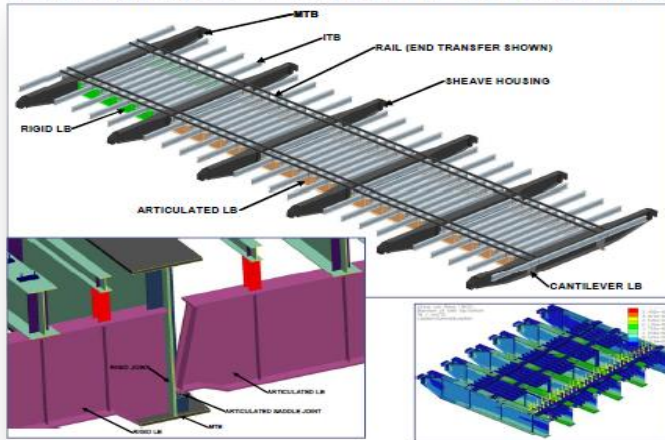

LIFT



CRADLES



ONGOING PROJECTS

- **Reconstruction of the Adm. Ferraz Station in Antarctica**
- **The Edictal was released last week by the government and is available at SECIRM's website;**
- **We are ready to plan the logistic part of personnel and material delivery to the site, as well as the logistic support during the construction using the best naval assets available.**



SHORT SPECIFICATION	
<u>Vessel spec. & features</u>	
MAIN DIMENSIONS	
LOA	262,6 m
LPP	232,0 m
BOA	32,2 m
Depth, Molded	18,3 m
Service Speed	18,0 knots
Summer Draft, SW	12,65 m
Deadweight, Summer Draft, SW	47 211 m.t
Light Ship Weight	22 030 m.t
Built	1989
GRT	38282
NET	11485
Classification	Det norske Veritas ✱1A1 ICE-1A*
Authorities	Panama
Trading area	World Wide
Flag	Panama
Home port	Panama
Call signal	HORB
Speed Max	19,7 knots
Speed loaded	18 knots
Main Engine	2 x B&W MAN 7DKRN80/160 (13704 kW each)
Propellers	2 x propellers.
Second Main engines	2 x Diesel electric 4 mW each
<u>Azimuting Thrusters</u>	2 x Azipod 3,5 mW each at stern
<u>Auxillaries</u>	4 off B&W MAN 500 kW 380V 50Hz
<u>Auxillaries for Bow thrusters</u>	3 x Diesel electric 2 mW each
<u>Bow thrusters</u>	3 x <u>Thunnel</u> thrusters 1,35 mW
DP 2 System	
Navigation aids	2 x Radars, 2 x Gyro, Magnetic compass, Autopilot, 2 x GPS, Electronic Chart navigation system, GMDSS A1 A2 A3, Inmarsat B, Inmarsat C, SEVSAT voice and WI FI system
<u>Accomodation</u>	150 persons



CONCLUSÕES

- **Extensive knowledge of the defense sector;**
- **Company affiliated to ABIMDE and SMERAS;**
- **Solid network of partners (national and international companies);**
- **Great knowledge and penetration in the BN (specially in PROSUB), BA, FAB, in the security organs of Brazil (PF, PM and MD) and in some Navies (USA, England, Argentina, Chile, Peru, Venezuela and Colombia);**
- **Great possibilities of developing new ventures in the defense area and in the civilian market (PPP, etc).**

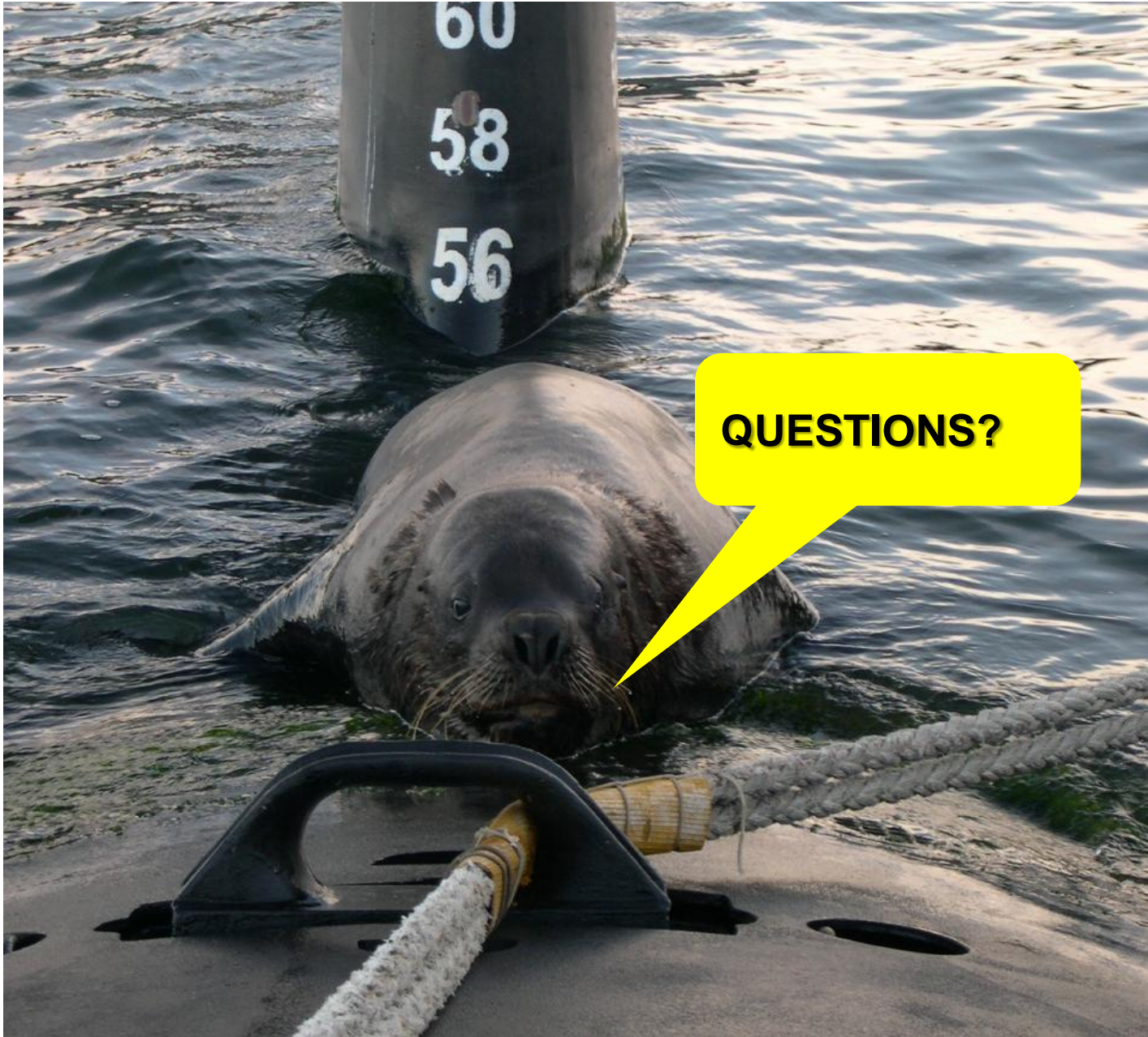

QUESTIONS?



THE END

